

- Galvanized steel furnace window
- Viewing opening \varnothing 54 mm
- Exchangeable protective glass
- For mounting flange \varnothing 200 mm
- Integrated air purging
- Protection against pollution and flames
- Holders for different sensors available



Product Characteristics

Type	HL 201
Art.-No.	9831J
Application	Material detection of objects in furnaces

Technical Data

Viewing opening	\varnothing 54 mm
Air connection	2x G3/8"
Air pressure	80 – 150 mbar over furnace pressure
Air consumption	approx. 60 - 130 l/min
Matching mounting flange	DN80, PN10, EN 1092-1
Ambient temperature	-40 ... +250 °C (without cooling)
Housing material	galvanized steel
Weight	approx. 8,5 kg

Dimension (mm)

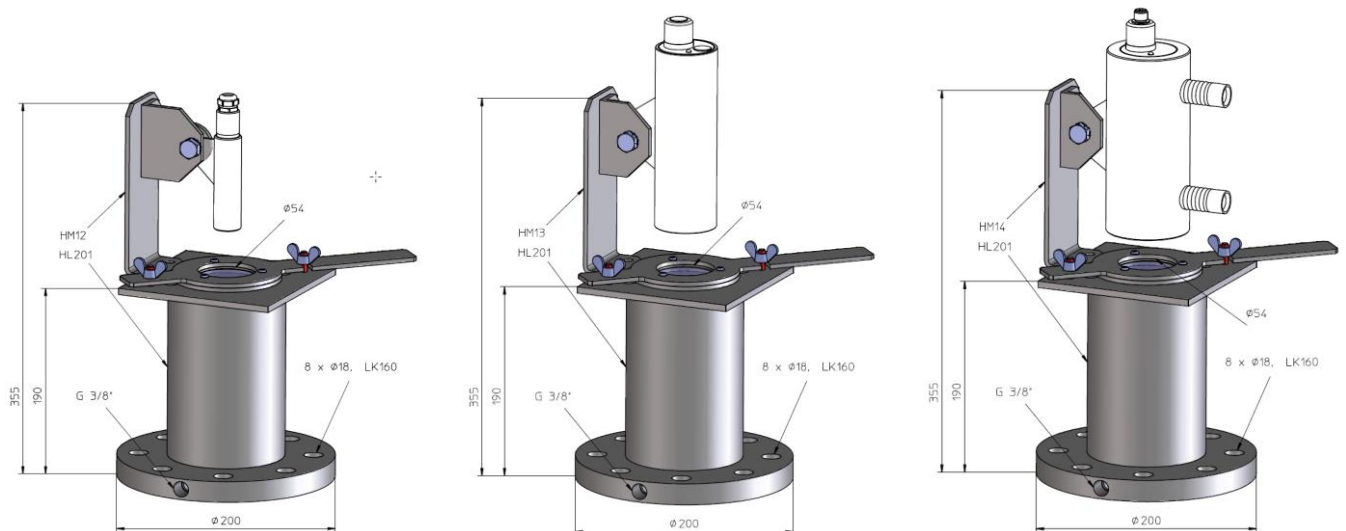

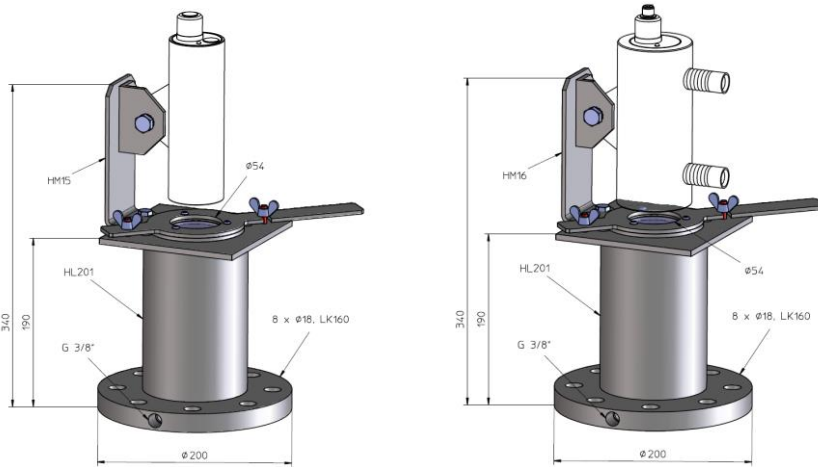

Accessories (in scope of supply)

	Type	Art.-No.
Protection glass temperature resistant	SG 3	9831C

Accessories (not in scope of supply)

	Type	Art.-No.
Holder for optic OACF	HM12	9816L
Holder for light barrier/HMD with stainless steel housing A Ø 57 mm	HM13	9816M
Holder for light barrier/HMD with cooling housing B Ø 76 mm	HM14	9816N
Holder for distance measuring sensor with stainless steel housing A Ø 57 / Ø 60,1 mm	HM15	9816O
Holder for distance measuring sensor with cooling housing B Ø 76 mm	HM16	9816P

Further information

	Document
Manual	BDA_HL133_HL201_D_E